

## Springvale EPS Ltd

Dinting Vale Works  
Glossop  
Derbyshire SK13 9LG

Tel: 01457 863211 Fax: 01457 869269  
e-mail: technical@springvale.com  
website: www.springvale.com



Agrément Certificate  
**08/4529**  
Product Sheet 2

### SPRINGVALE EPS ROOF INSULATION

### SPRINGVALE HYDROSHIELD FOR INVERTED ROOF INSULATION

This Agrément Certificate Product Sheet<sup>(1)</sup> relates to Springvale Hydroshield for Inverted Roof Insulation, which uses expanded polystyrene (EPS 200E and EPS 300E), a water-reducing layer and ballast or paving protection for inverted flat untrafficked roofs and balconies and terraced roofs subject to pedestrian access only. The products are available in both uniform thickness and tapered board options and may be used with zero pitch and slopes between 1:80 and 1:6. When used in conjunction with a suitable root barrier, the Springvale Hydroshield EPS 300E may only be used in green roof applications.

(1) Hereinafter referred to as 'Certificate'.

#### CERTIFICATION INCLUDES:

- factors relating to compliance with Building Regulations where applicable
- factors relating to additional non-regulatory information where applicable
- independently verified technical specification
- assessment criteria and technical investigations
- design considerations
- installation guidance
- regular surveillance of production
- formal three-yearly review.

#### KEY FACTORS ASSESSED

**Thermal performance** — the products can contribute towards the thermal performance of a roof. The design thermal conductivity ( $\lambda_d$ ), including moisture correction factor, of the products is  $0.038 \text{ W}\cdot\text{m}^{-1}\cdot\text{K}^{-1}$  (see section 6).

**Condensation risk** — the products can contribute to limiting the risk of surface and interstitial condensation (see section 7).

**Resistance to foot traffic** — the products, when installed on appropriate decks finished with a gravel ballast layer, paving slabs or a green roof, can be used on untrafficked roofs with limited pedestrian access associated with maintenance operations, and pedestrian access roofs (on balconies and roof terraces) subject to foot traffic only (see section 8).

**Durability** — the products will remain effective as an insulant for at least 25 years, as long as the water-reducing layer membrane is in place (see section 12).



The BBA has awarded this Certificate to the company named above for the products described herein. These products have been assessed by the BBA as being fit for their intended use provided they are installed, used and maintained as set out in this Certificate.

On behalf of the British Board of Agrément

Date of Second issue: 22 December 2016

John Albon — Head of Approvals

Claire Curtis-Thomas

Originally certificated on 16 May 2011

Construction Products

Chief Executive

*The BBA is a UKAS accredited certification body — Number 113. The schedule of the current scope of accreditation for product certification is available in pdf format via the UKAS link on the BBA website at [www.bbacerts.co.uk](http://www.bbacerts.co.uk)*

*Readers are advised to check the validity and latest issue number of this Agrément Certificate by either referring to the BBA website or contacting the BBA direct.*

British Board of Agrément

Bucknalls Lane  
Watford  
Herts WD25 9BA

tel: 01923 665300  
fax: 01923 665301  
[clientservices@bba.star.co.uk](mailto:clientservices@bba.star.co.uk)  
[www.bbacerts.co.uk](http://www.bbacerts.co.uk)

©2016

# Regulations

In the opinion of the BBA, Springvale Hydrosshield for Inverted Roof Insulation, if installed, used and maintained in accordance with this Certificate, can contribute to satisfying the relevant requirements of the following Building Regulations (the presence of a UK map indicates that the subject is related to the Building Regulations in the region or regions of the UK depicted):



## The Building Regulations 2010 (England and Wales) (as amended)

Requirement:	C2(c)	Resistance to moisture
Comment:		The products can contribute to satisfying this Requirement. See sections 7.4 and 7.5 of this Certificate.
Requirement:	L1(a)(i)	Conservation of fuel and power
Comment:		The products can contribute to satisfying this Requirement. See sections 6.1 and 6.4 of this Certificate.
Regulation:	7	Materials and workmanship
Comment:		The products are acceptable. See section 12.1 and the <i>Installation</i> part of this Certificate.
Regulation:	26	CO <sub>2</sub> emission rates for new buildings
Regulation:	26A	Fabric energy efficiency rates for new dwellings (applicable to England only)
Regulation:	26A	Primary energy consumption rates for new buildings (applicable to Wales only)
Regulation:	26B	Fabric performance values for new dwellings (applicable to Wales only)
Comment:		The products can contribute to satisfying these Regulations. See sections 6.1 and 6.4 of this Certificate.



## The Building (Scotland) Regulations 2004 (as amended)

Regulation:	8(1)(2)	Durability, workmanship and fitness of materials
Comment:		The products are acceptable. See sections 11.1 and 12.1 and the <i>Installation</i> part of this Certificate.
Regulation:	9	Building standards applicable to construction
Standard:	3.15	Condensation
Comment:		The products can contribute to satisfying this Standard, with reference to clauses 3.15.1 <sup>(1)(2)</sup> , 3.15.3 <sup>(1)(2)</sup> , 3.15.4 <sup>(1)(2)</sup> , 3.15.5 <sup>(1)(2)</sup> , and 3.15.6 <sup>(1)(2)</sup> . See sections 7.4 and 7.6 of this Certificate.
Standard:	6.1(b)	Carbon dioxide emissions
Standard:	6.2	Building insulation envelope
Comment:		The products can contribute to satisfying these Standards, with reference to clauses, or parts of, 6.1.1 <sup>(1)</sup> , 6.1.2 <sup>(1)(2)</sup> , 6.1.4 <sup>(1)(2)</sup> , 6.1.5 <sup>(1)</sup> , 6.1.6 <sup>(1)(2)</sup> , 6.1.7 <sup>(2)</sup> , 6.1.8 <sup>(2)</sup> to 6.1.10 <sup>(2)</sup> , 6.2.1 <sup>(1)(2)</sup> , 6.2.2 <sup>(1)</sup> , 6.2.3 <sup>(1)(2)</sup> , 6.2.4 <sup>(1)(2)</sup> , 6.2.5 <sup>(2)</sup> , 6.2.6 <sup>(1)(2)</sup> to 6.2.11 <sup>(1)(2)</sup> , 6.2.12 <sup>(2)</sup> and 6.2.13 <sup>(1)(2)</sup> . See sections 6.1 and 6.4 of this Certificate.
Standard:	7.1(a)(b)	Statement of sustainability
Comment:		The products can contribute to satisfying the relevant requirements of Regulation 9, Standards 1 to 6, and therefore will contribute to a construction meeting a bronze level of sustainability as defined in this Standard. In addition, the products can contribute to a construction meeting a higher level of sustainability as defined in this Standard, with reference to clauses 7.1.4 <sup>(1)(2)</sup> [Aspects 1 <sup>(1)(2)</sup> and 2 <sup>(1)</sup> ], 7.1.6 <sup>(1)(2)</sup> [Aspects 1 <sup>(1)(2)</sup> and 2 <sup>(1)</sup> ] and 7.1.7 <sup>(1)(2)</sup> [Aspect 1 <sup>(1)(2)</sup> ]. See section 6.1 of this Certificate.
Regulation:	12	Building standards applicable to conversions
Comment:		All comments given for the products under Regulation 9, Standards 1 to 6, also apply to this Regulation, with reference to clause 0.12.1 <sup>(1)(2)</sup> and Schedule 6 <sup>(1)(2)</sup> . (1) Technical Handbook (Domestic). (2) Technical Handbook (Non-Domestic).



## The Building Regulations (Northern Ireland) 2012 (as amended)

Regulation:	23	Fitness of materials and workmanship
Comment:		The products are acceptable. See section 12.1 and the <i>Installation</i> part of this Certificate.
Regulation:	29	Condensation
Comment:		The products can contribute to satisfying this Regulation. See section 7.4 of this Certificate.
Regulation:	39(a)(i)	Conservation measures
Comment:		The products can contribute to satisfying this Regulation. See sections 6.1 and 6.4 of this Certificate.
Regulation:	40(2)	Target carbon dioxide emission rate
Comment:		The products can contribute to satisfying this Regulation. See sections 6.1 and 6.4 of this Certificate.

## Construction (Design and Management) Regulations 2015

## Construction (Design and Management) Regulations (Northern Ireland) 2016

Information in this Certificate may assist the client, designer (including Principal Designer) and contractor (including Principal Contractor) to address their obligations under these Regulations.

See sections: 1 *Description* (1.1 and 1.2) and 3 *Delivery and site handling* (3.3 and 3.4) of this Certificate.

# Additional Information

## NHBC Standards 2016

NHBC accepts the use of Springvale Hydrosshield for Inverted Roof Insulation, provided it is installed, used and maintained in accordance with this Certificate, in relation to *NHBC Standards, Chapter 7.1 Flat roofs and balconies*.

## CE marking

The Certificate holder has taken the responsibility of CE marking the products in accordance with harmonised European Standard BS EN 13163 : 2012. An asterisk (\*) appearing in this Certificate indicates that data shown are given in the manufacturer's Declaration of Performance.

# Technical Specification

## 1 Description

1.1 Springvale Hydrosshield For Inverted Roof Insulation consists of lap jointed Hydrosshield EPS 200E and EPS 300E expanded polystyrene (EPS) board (see Figure 1 and Table 1) made from low water absorption polystyrene bead and a Hydrosshield water reducing layer (nominal characteristics given in Table 2).

Figure 1 Lap joints

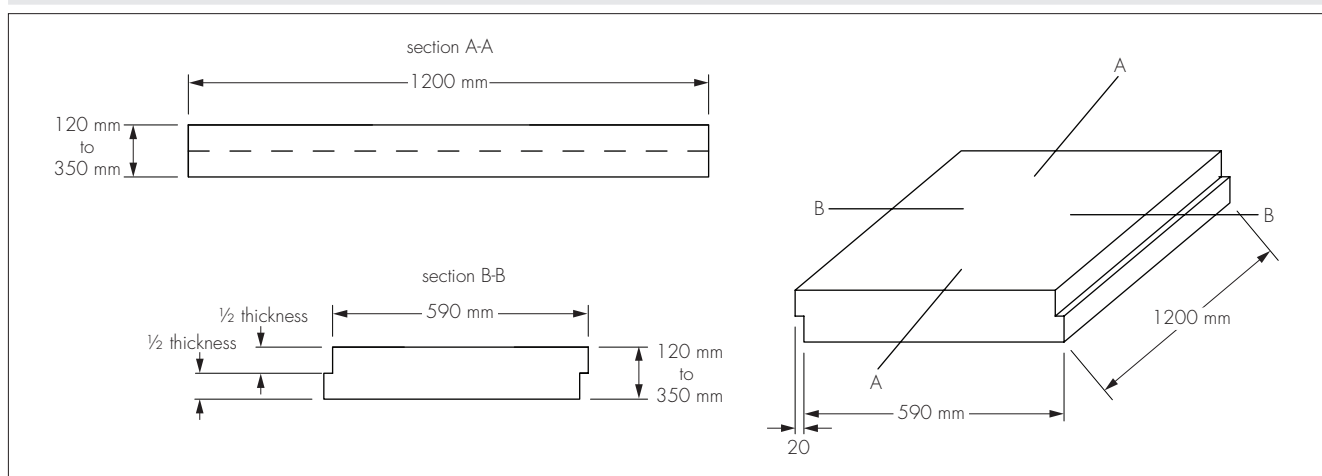

Table 1 Physical properties of EPS component

Nominal characteristic and level	
Grade	EPS 200E and EPS 300E
Minimum compressive strength* at 10% compression (kPa)	CS (10) 200 and CS (10) 300
Minimum bending strength (kPa)	BS 250
Water vapour resistivity (MN.s.g <sup>-1</sup> .m <sup>-1</sup> )	514
Density (kg.m <sup>-3</sup> )	30 to 32
Length (mm)	1200 (L3)
Width (mm)	590 (W3)
Flatness	10 mm per 1000 mm
Squareness	5 mm difference between diagonals
Thickness (mm)	120, 150, 190, 200 to 350 (T2)

1.2 The Hydrosshield water-reducing layer has the nominal properties shown in Table 2.

Table 2 Physical properties of the water-reducing layer component

Nominal characteristic and level	
Mass per unit area (g.m <sup>-2</sup> )	120
Roll length (m)	50
Roll width (mm)	1.0 to 1.5
Water vapour resistance (MN.s.g <sup>-1</sup> )	0.16

1.3 A suitable root barrier is used in the green roof applications. Laps in the root barrier are sealed using a suitable root barrier tape. The root barrier has the nominal properties shown in Table 3 and should be covered by a test report confirming satisfactory performance when tested to BS EN 13948 : 2007. The Certificate holder can advise on suitable materials for this purpose.

*Table 3 Physical properties of the root barrier (for green roof applications)*

Nominal characteristics	
Material type (water permeable root barrier)	Non-woven polypropylene/polyethylene
Roll length (m)	25
Roll width (m)	2 and 4
Thickness (mm)	0.75
Water vapour transmission ( $\text{kg}\cdot\text{m}^{-2}\cdot\text{s}^{-1}\cdot\text{Pa}^{-1}$ )	$1.5 \times 10^{-9}$
Resistance to static loading (N)	200
Joint strength, tape ( $\text{N}\cdot 50 \text{ mm}^{-1}$ )	> 60 N
Dimensional stability (%)	2
Lap joints (mm) with suitable root barrier	300

1.4 Ancillary items for use with the products but outside the scope of this Certificate include:

- Hydrosshield sealing tape for joining laps in the water-reducing layer
- Stickband for sealing around penetrations
- gravel ballast washed, rounded and be nominal 20 to 40 mm in size, laid to a minimum depth of 50 mm, or
- paving of minimum 40 mm thickness. See section 9.1 and 9.2
- green roof finish, including root barrier, filter fleece and drainage/water retention layer to manufacturer's specification which also meet the relevant requirements of ETAG 031 : 2010 (see section 4.10).

## 2 Manufacture

2.1 Raw material polystyrene bead is expanded and moulded to form EPS block using steam.

2.2 As part of the assessment and ongoing surveillance of products quality, the BBA has:

- agreed with the Certificate holder/manufacturer the quality control procedures and products testing to be undertaken
- assessed and agreed the quality control operated over batches of incoming materials
- monitored the production process and verified that it is in accordance with the documented process
- evaluated the process for management of nonconformities
- checked that equipment has been properly tested and calibrated
- undertaken to carry out the above measures on a regular basis through a surveillance process, to verify that the specifications and quality control operated by the manufacturer are being maintained.

2.3 The management system of Springvale EPS Ltd has been assessed and registered as meeting the requirements of BS EN ISO 9001 : 2008 by BSI Quality Management System and BS EN ISO 14001 : 2004 by QMS (Certificate Nos. FM13871 and 14130944 respectively).

## 3 Delivery and site handling

3.1 Springvale Hydrosshield for Inverted Roof Insulation is delivered to site shrink wrapped on wooden pallets, or on disposable polystyrene skids. The products are marked with a coloured stripe to indicate the grade. A label is attached to each stack of the products, detailing the products name, board size, grade, date of manufacture and QA reference.

3.2 The products must be protected from prolonged exposure to sunlight and should be stored under cover or protected with light-coloured opaque polythene sheets.

3.3 Care must be taken to avoid contact with solvents and materials containing organic components.

3.4 The products must be stored flat, off the ground, on a clean, level surface and under cover to protect them from high winds. They must not be exposed to open flame or other ignition sources.

3.5 Damaged boards must not be used.

## Assessment and Technical Investigations

The following is a summary of the assessment and technical investigations carried out on Springvale Hydrosshield for Inverted Roof Insulation.

## 4 Use

4.1 Springvale Hydrosshield for Inverted Roof Insulation is suitable for use on inverted flat roofs or zero pitch untrafficked roofs, and balconies and terraced roofs subject to pedestrian access only, with a gravel ballast or paved finish on a suitably designed timber, concrete or metal structural deck and appropriate fully supported waterproofing system (see Figure 2). In addition, Springvale Hydrosshield EPS 300E is suitable for use with a green roof.

Figure 2 Example of inverted roof system on concrete decking

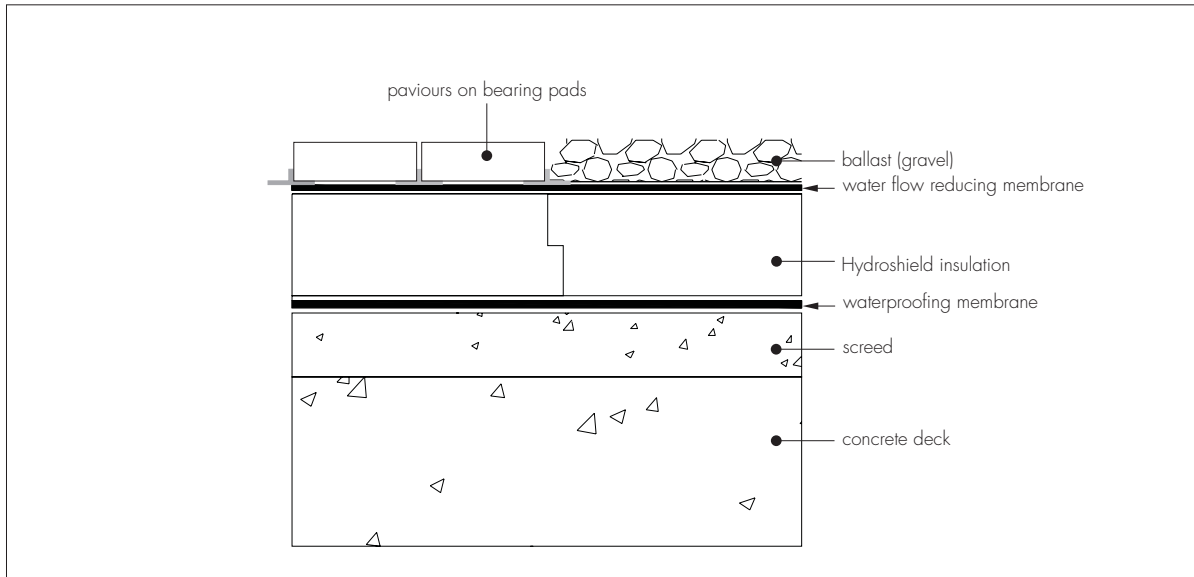

4.2 For the purpose of this Certificate:

- flat roofs are defined as those roofs having a finished fall of between 1:80 and 1:6, and zero pitch as finished falls from 0 to 1:80. For design purposes on sloping flat roofs, twice the minimum finished fall should be assumed, unless a detailed analysis of the roof is available, including overall and local deflection, direction of falls etc. See also *BBA Information Bulletin No 4*
- untrafficked roofs are defined as those roofs subject only to pedestrian traffic during installation of the system and to carry out maintenance of the roof covering and cleaning of gutters. Pedestrian access roofs (balconies and terraced roofs only) are defined as those roofs subject only to foot traffic and gathering of people no greater than that required for maintenance. Traffic in excess of the above criteria is outside the scope of this Certificate and special precautions, such as the use of higher compressive strength grade insulation and additional protection to the waterproofing membrane, will be necessary
- green roofs are defined and restricted. Other green roof types and roof gardens are not covered by this Certificate.

4.3 A roof ballast layer must be installed as work progresses, to protect the insulation boards and the membrane from the effects of wind uplift and UV degradation. The ballasted roof finish may be either gravel ballast, paving or a green roof system, which must be assessed by a specialist for its suitability according to region exposure and building height. In addition, the dead load imposed by the finish (including the saturated weight of a green roof) must be allowed for in calculating the total acceptable load on the deck. Care must be taken to ensure that upgraded roofs are capable of carrying the increased load and depth of the installed system. Ballast must not be stacked in one place on the roof unless the roof is capable of supporting it.

4.4 Gravel ballast should be a washed low fines aggregate, rounded and of nominal 20 to 40 mm in size, laid to a minimum thickness of 50 mm. The minimum size of ballast depends on the wind loads and parapet height to prevent wind scour of the ballast. The ballast should be installed in accordance with BS EN 1991-1-4 : 2005 and its UK National Annex.

4.5 The gravel ballast specification given in section 4.4 is suitable for use in sheltered regions or buildings up to 10 storeys. On buildings up to 15 storeys, this specification may be used but the perimeter must be loaded with paving determined by reference to BS EN 1991-1-2 : 2002. For other exposure conditions or tall buildings, specialist advice should be sought.

4.6 A paving finish ballast comprising a minimum 40 mm of standard pressed concrete paving slabs is suitable in sheltered regions and in buildings up to 15 storeys. For other exposure conditions or tall buildings, specialist advice should be sought.

4.7 Recommendations for the design of green roof specifications are available within the latest edition of *The GRO Green Roof Code — Green Roof Code of Best Practice for the UK*.

4.8 *The Green Roof Guide* states that for inverted roofs, a green roof acts as ballast, provided the weight of the green roof is the same as a required gravel ballast finish. The growing medium must have resistance to wind and water erosion and be spread over a suitable filter and drainage layer. The green roof covering should be assessed for wind uplift with sufficient growing medium weight calculated for roof ballast. The green roof specification, including growing medium, geotextile filter fleece and drainage/water-retention layer is to be determined by the specialist supplier.

4.9 The products must always be overlaid with the water-reducing membrane, which acts as a water flow reducing layer minimising cold rainwater flowing between the insulation and the roof waterproofing with consequent heat loss.

4.10 In green roof applications, the boards must be overlaid first with the membrane, and the root barrier installed to prevent root penetration, before finishing with the green roof specification.

4.11 The water-reducing membrane is to be laid with 300 mm laps, overlapping in the downward direction of the flat roof slope. At upstands and penetrations the membrane must be turned up to finish above the surface of the ballast layer and turned down at drainage outlets.

4.12 Timber, concrete or metal roofs should be designed in accordance with the relevant provisions of BS 6229 : 2003, BS 8217 : 2005 and BS 8218 : 1998, in particular to accommodate the weight of the ballast layer.

4.13 Decks should be covered with one or more of the following roof waterproofing specifications:

- built-up specifications using reinforced bitumen membranes to BS 8747 : 2007 in accordance with the recommendations of Table 5 of the Standard, and installed to the relevant clauses of BS 8217 : 2005
- mastic asphalt laid in accordance with BS 8218 : 1998
- other waterproofing systems which are the subject of a current Agrément Certificate, laid in accordance with, and within the limitations imposed by, that Certificate.

4.14 The roof must be designed with adequate falls unless the roof waterproofing system has been specifically designed and covered by a valid BBA Certificate for use in a zero pitch roof application (see section 4.2). For zero pitch roofs it is particularly important to identify the correct drainage points, to ensure that drainage is sufficient and effective. Reference should be made to the appropriate clauses of the LRWA Guidance Note No. 7 — *Specifier guidance for flat roof falls*, which generally requires surface drainage falls in most situations.

4.15 It is essential that roof falls and drainage paths are correctly designed to avoid ponding and subsequent risk of silt build up, stresses in freezing conditions and to reduce water entry in the event of a failure in the waterproofing layer.

4.16 Tapered insulation boards may be used where appropriate, to achieve the minimum finished falls required. Any existing irregularities in the roof should be overcome before a tapered system is laid.

4.17 Dual level roof drainage should be provided in accordance with BS 6229 : 2003 and BS EN 12056-3 : 2000 to drain water off at the level of the water-reducing membrane and also at the level of the roof waterproofing. See Figure 3.

4.18 Drainage points need to be located at the lowest point of the roof, to facilitate the effective removal of rainwater. Care is needed to identify these locations. For example, precast concrete decks will deflect between spans, and mid-span may be the lowest point of the roof rather than roof edges or column supports.

4.19 The drainage system for green roofs must be correctly designed and provision made for access for maintenance purposes. Dead loads for green roofs can increase if the drains become partially or completely blocked causing waterlogging of the drainage layer. Gravel guards should be used on rainwater outlets and these should be inspected annually.

4.20 Where there is a risk from plasticiser migration or other contaminants from the roof waterproofing (such as PVC single ply membranes) a suitable plastic fibre or similar isolating sheet must be interposed between the roof waterproofing and the EPS insulation boards. For loose laid single layer roof waterproofing membranes, a cushion layer should be interposed.

## 5 Practicability of installation

The products are designed to be installed by a competent general builder, or contractor, experienced with these types of products.

## 6 Thermal performance



6.1 Calculations of thermal transmittance (U value) of a specific roof construction should be carried out in accordance with BS EN ISO 6946 : 2007, BRE Report BR 443 : 2006 and section 6.2 of this Certificate, using the design thermal conductivity ( $\lambda_d$ ) (including moisture correction factor), and the  $f_x$  drainage factor for the system as given below:

- $0.038 \text{ W}\cdot\text{m}^{-1}\cdot\text{K}^{-1}$  — design thermal conductivity ( $\lambda_d$ ) [which is the declared lambda ( $\lambda_p$ ) with addition of moisture correction] for EPS 200 E
- $f_x = 0.001$  — drainage factor for systems incorporating the Hydrosshield water-reducing layer.

See also BBA Information Bulletin No 4.



6.2 The U value of a completed roof will depend on the insulation thickness, and type of substrate and internal finish. When considering insulation requirements, designers should refer to the detailed guidance contained in the documents supporting the national Building Regulations. The U values shown in Table 4 indicate that the products can contribute to a roof achieving typical U values referred to in those supporting documents.

**Table 4 Example U values for flat roof and zero pitch applications (incorporating the Hydrosshield membrane)**

U value (W·m <sup>-2</sup> ·K <sup>-1</sup> )	Deck type	Insulation thickness required for different precipitation (mm)				
		$p^{(1)} = 1$	$p^{(1)} = 2$	$p^{(1)} = 3$	$p^{(1)} = 8$	$p^{(1)} = 10$
0.13	(2)	300	300	320	320	— <sup>(4)</sup>
	(3)	300	300	300	320	320
0.15	(2)	— <sup>(4)</sup>	— <sup>(4)</sup>	— <sup>(4)</sup>	— <sup>(4)</sup>	— <sup>(4)</sup>
	(3)	250	250	250	— <sup>(4)</sup>	— <sup>(4)</sup>
0.16	(2)	250	250	250	250	— <sup>(4)</sup>
	(3)	— <sup>(4)</sup>	— <sup>(4)</sup>	— <sup>(4)</sup>	250	250
0.18	(2)	— <sup>(4)</sup>	— <sup>(4)</sup>	— <sup>(4)</sup>	— <sup>(4)</sup>	— <sup>(4)</sup>
	(3)	200	200	— <sup>(4)</sup>	— <sup>(4)</sup>	— <sup>(4)</sup>
0.20	(2)	190	190	190	200	200
	(3)	— <sup>(4)</sup>	— <sup>(4)</sup>	— <sup>(4)</sup>	190	190
0.25	(2)	150	150	150	150	— <sup>(4)</sup>
	(3)	— <sup>(4)</sup>	— <sup>(4)</sup>	— <sup>(4)</sup>	— <sup>(4)</sup>	150

(1) Values for  $p$  taken as examples of best to worst case for all UK locations.

(2) Dense deck with plaster on dabs — a dense concrete roof deck with a minimum thermal resistance of 0.08 m<sup>2</sup>·K·W<sup>-1</sup>.

(3) Dense deck with suspended plasterboard ceiling.

(4) For improved thermal/carbon emission performance, additional batten/insulation thicknesses should be considered.

6.3 Rainfall reaching the roof waterproofing membrane will temporarily affect the rate of heat loss from the roof and should be accounted for by adding a correction ( $\Delta U_r$ ) to the calculated roof U value in accordance with Annex D4 of BS EN ISO 6946 : 2007, as follows:

$\Delta U_r = pfx (R_1/R_T)^2$  where:

$\Delta U_r$  = correction to the calculated thermal transmittance of the roof element (W·m<sup>-2</sup>·K<sup>-1</sup>).

$p^{(1)}$  = average rate of precipitation during the heating season (mm·day<sup>-1</sup>).

$f$  = drainage factor giving the fraction of  $p$  reaching the waterproof membrane.

$x$  = factor for increased heat loss caused by rainwater flowing on the membrane (W·day·m<sup>-2</sup>·K<sup>-1</sup>·mm<sup>-1</sup>).

$R_1$  = thermal resistance of the layer of the insulation above the waterproofing membrane (m<sup>2</sup>·K·W<sup>-1</sup>).

$R_T$  = total thermal resistance of the construction before application of the correction (m<sup>2</sup>·K·W<sup>-1</sup>).

$fx$  = 0.001 for the system with ballast protection.

(1) Values for average rainfall during the heating season for different UK locations can be found at [www.metoffice.gov.uk/climate/uk/averages/19611990/images/RainOctMar6190.gif](http://www.metoffice.gov.uk/climate/uk/averages/19611990/images/RainOctMar6190.gif) and divided by 182 days to obtain ' $p$ ' in mm·day<sup>-1</sup>.

## Junctions



6.4 Care must be taken in the overall design and construction of junctions with other elements and openings to minimise thermal bridges and air infiltration. Detailed guidance can be found in the documents supporting the national Building Regulations.

## 7 Condensation risk

7.1 Warm water trapped under the products is likely to be replaced by colder water during rainfall. Therefore, during heavy or continuous rainfall the roof waterproofing and the deck will be cooled. If condensation does occur it will be short-term, disappearing when the rain stops.

7.2 Risk of interstitial condensation will be minimal with concrete decks but metal and timber decks will be subjected to short periods of moisture; therefore timber must be treated with a suitable preservative in accordance with BS 8417 : 2011.

7.3 For systems using paving or a green roof finish, a condensation risk analysis may be necessary using dynamic software in accordance with BS EN 15026 : 2007, depending on the climatic conditions existing in the location where it is installed.

### Interstitial condensation



7.4 Roofs will adequately limit the risk of interstitial condensation when they are designed and constructed in accordance with BS 5250 : 2011, Section 8.4 and Appendix D. Further guidance may be obtained from BRE Report BR 262 : 2002.

### Surface condensation



7.5 Roofs will adequately limit the risk of surface condensation when the thermal transmittance (U value) does not exceed 0.35 W·m<sup>-2</sup>·K<sup>-1</sup> at any point and the junctions with walls are designed in accordance section 6.4 of this Certificate.



7.6 Roofs will adequately limit the risk of surface condensation when the thermal transmittance (U value) does not exceed  $1.2 \text{ W}\cdot\text{m}^{-2}\cdot\text{K}^{-1}$  at any point. Guidance may be obtained from BS 5250 : 2011, Section 8. Further guidance may be obtained from BRE Report BR 262 : 2002 and section 6.4 of this Certificate.

## 8 Resistance to foot traffic

The products have adequate resistance to the loads associated with light maintenance traffic on roofs, and to pedestrian foot traffic on balconies and roof terraces.

## 9 Behaviour in relation to fire

9.1 Springvale Hydrosshield For Inverted Roof Insulation has a reaction to fire Classification\* of E to BS EN 13501-1 : 2007.

9.2 When ballasted with an aggregate (minimum depth of 50 mm), or fully supported pressed concrete paving slabs of at least 40 mm thickness, the roof may be considered to be of designation AA (low vulnerability in Scotland) and so is unrestricted by the national Building Regulations.

9.3 The designation of other roof covering specifications should be confirmed as required by the national Building Regulations.

9.4 Springvale Hydrosshield for Inverted Roof Insulation boards should not be laid over compartment walls.

## 10 Effect on roof covering

The protected inverted roof system will provide solar protection and also limit the range of temperature to which the waterproofing membrane will be subjected. Placing the insulation on top of the roof covering will normally lead to an extended life of the waterproof membrane.

## 11 Maintenance



11.1 The inverted roof should require little or no maintenance, other than annual removal of any plants (in the case of gravel/paving finish), cleaning/checking of water outlets and gutters if necessary and checking that the gravel ballast is still in place and not interfering with or blocking gullies or outlets. Any displaced ballast, for example by wind scouring, should be promptly returned to its original state.

11.2 The use of chemicals (eg weed killers) should be checked for compatibility with the insulation, the membrane and the deck waterproofing layer. The manufacturer can advise on the suitability of a particular product.

11.3 Leaks in the waterproof membrane can be accessed by removal of the gravel ballast, paving or green roof covering, root barrier (green roof only) membrane and insulation boards, taking care not to damage the water-reducing layer.

11.4 Protected inverted roofs can be upgraded by the addition of insulation so long as there is sufficient height in the parapets and roof lights. This may also require additional ballast, therefore the structural deck must be adequate to support the extra loading from the increase in weight.

11.5 The Certificate holder must approve any upgrading using a loose layer of insulation on top of the existing insulation.

## 12 Durability



12.1 The products are rot resistant and, as long as the water-reducing layer remains undamaged, will have a life at least 25 years under normal circumstances.

12.2 Care must be taken to ensure that the gravel ballast or paving/green roof covering, once installed, provides cover to the membrane at all times to avoid UV degradation of the water-reducing layer.

# Installation

## 13 General

13.1 Springvale Hydrosshield For Inverted Roof Insulation is laid over a compatible and complete waterproofing system, generally starting at the point of access in a brick bond pattern.

13.2 The products must be laid flat and tightly interlocked to prevent gaps in the insulation layer. Insulation boards are laid in advancing front, with membrane (water-reducing layer) on top, and the ballast, paving or green roof covering laid as soon as possible to protect the system.

13.3 Where necessary, the products are cut accurately with a fine tooth saw or with a hot wire cutter around any penetrations.

13.4 The water-reducing layer must be laid and sealed with Hydrosshield tape immediately after positioning the products. Care should be taken to seal around all upstands with Hydrosshield sealing tape and penetrations with Stickband tape (see Figure 3).



Figure 3 Installation of the Hydrosshield system (all dimensions in mm)

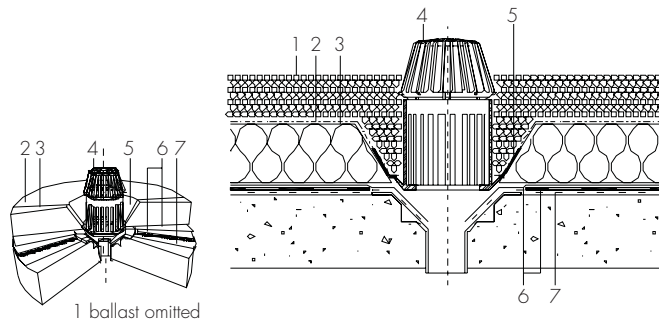

- 1 20 - 40 mm rounded aggregate ballast with no-fines installed to a minimum depth of 50 mm
- 2 water reducing layer
- 3 Hydrosshield EPS insulation to achieve design U value
- 4 rainwater outlet
- 5 Hydrosshield tape
- 6 structural waterproofing system
- 7 primer

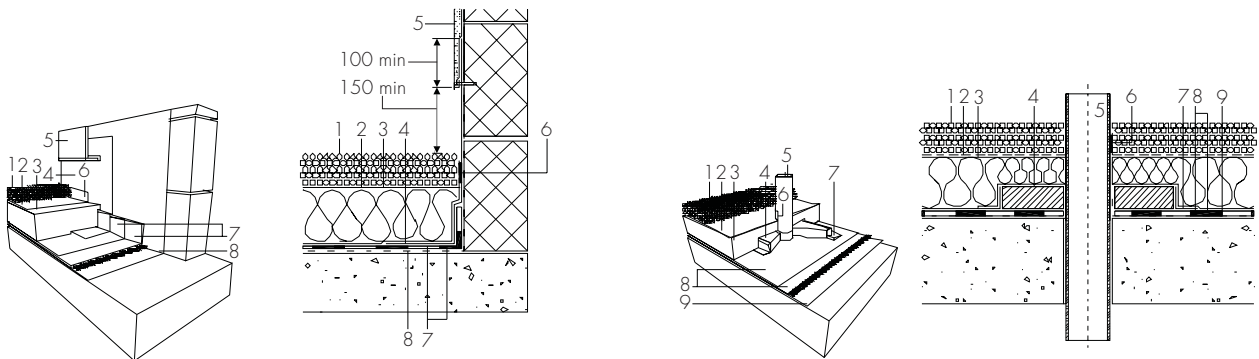

- 1 20 - 40 mm rounded aggregate ballast with no-fines installed to a minimum depth of 50 mm
- 2 water reducing layer
- 3 Hydrosshield EPS insulation to achieve design U value
- 4 waterproofing detail membrane
- 5 render
- 6 Hydrosshield tape
- 7 structural waterproofing system
- 8 primer

- 1 20 - 40 mm rounded aggregate ballast with no-fines installed to a minimum depth of 50 mm
- 2 water reducing layer
- 3 Hydrosshield EPS insulation to achieve design U value
- 4 compound to form pitch pocket
- 5 cold pipe
- 6 Hydrosshield tape
- 7 bonded retaining angle
- 8 structural waterproofing system
- 9 primer

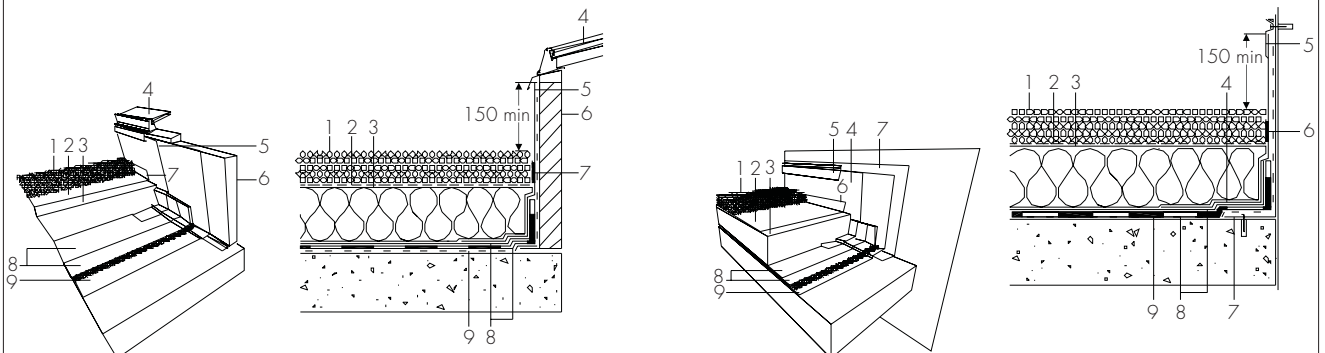

- 1 20 - 40 mm rounded aggregate ballast with no-fines installed to a minimum depth of 50 mm
- 2 water reducing layer
- 3 Hydrosshield EPS insulation to achieve design U value
- 4 access hatch/rooflight
- 5 waterproofing detail membrane
- 6 insulated access hatch curb
- 7 Hydrosshield tape
- 8 structural waterproofing system
- 9 primer

- 1 20 - 40 mm rounded aggregate ballast with no-fines installed to a minimum depth of 50 mm
- 2 water reducing layer
- 3 Hydrosshield EPS insulation to achieve design U value
- 4 waterproofing detail membrane
- 5 termination bar to suit building construction
- 6 Hydrosshield tape
- 7 bonded aluminium upstand
- 8 structural waterproofing system
- 9 primer

13.5 The products are laid in an advancing front together with the water-reducing layer to ensure that the ballast is adequately distributed as soon as possible to protect the products.

### **Procedure**

#### **Gravel ballast finish**

13.6 In order to prevent flotation, wind uplift and UV degradation, the system must be covered with gravel ballast to a minimum thickness of 50 mm.

13.7 It is essential that the ballast is carefully placed directly over the water-reducing membrane laid with 300 mm unsealed lap joints, and that complete depth and cover is achieved over the entire surface of the system.

13.8 Gravel must not contain excessive fines in order to prevent clogging of gullies and outlets and to discourage organic growth.

#### **Paving slab finish**

13.9 Pressed concrete paving slabs of at least 40 mm thickness, must meet the requirements of sections 7.3 and 9 of this Certificate. Paving slabs can either be laid fully supported, or may be supported using proprietary spacer pads in accordance with the manufacturer's instructions.

13.10 The paving slab finish is laid directly over the water-reducing membrane laid with 300 mm unsealed lap joints.

#### **Green Roof finish**

13.11 The root barrier is to be installed directly on top of the water-reducing membrane. Root barrier tape is used to seal 300 mm laps in the root barrier, in accordance with manufacturer's instructions.

13.12 The green roof system including growing medium, geotextile filter fleece, and water retention/drainage layer etc, is installed in accordance with the manufacturer's instructions, on top of the root barrier.

13.13 All upstands, roof perimeters, drainage outlets and other protrusions through the green roof, should be protected by minimum of 500 mm wide un-vegetated barrier such as 20 to 40 mm rounded gravel aggregate or concrete paving slabs.

#### **Tapered boards for zero pitch — Falls**

13.14 Where a fall is required, for example in zero pitch flat roofs, tapered boards are then used. These falls are coded to the requirements of the specific building, as noted on the Certificate holder's roof layout drawing.

13.15 To provide a uniform fall it is essential that the deck is even and true. Any irregularities such as hollows, backfalls or depressions must be levelled prior to laying the boards.

13.16 Boards are laid directly on top of the roof waterproofing membrane, sequentially in accordance with the position code number/letter on the roof layout drawing. Laying of the tapered insulation should commence at points indicated on the layout drawing.

13.17 The tapered boards are carefully ballasted as soon as possible to protect the system.

## **Technical Investigations**

### **14 Tests**

A water-reducing layer flow rate test was carried out in accordance with ETAG 031 : 2010 for Springvale Hydrosshield For Inverted Roof Insulation and the results assessed to determine:

- thermal conductivity
- moisture correction
- bending strength
- green roof assessment
- root barrier
- dimensional stability
- resistance to freeze/thaw of the thermal insulation.

### **15 Investigations**

15.1 Independent data relating to the following were examined:

- thermal conductivity
- moisture correction
- compressive strength
- density
- long term water absorption
- a dynamic consideration risk analysis (to BS EN 15026 : 2007) was carried out.

15.2 The manufacturing process was evaluated, including the methods adopted for quality control, and details were obtained of the quality and composition of the materials used.

## Bibliography

- BS 5250 : 2011 + A1 : 2016 *Code of practice for control of condensation in buildings*
- BS 6229 : 2003 *Flat roofs with continuously supported coverings — Code of practice*
- BS 8217 : 2005 *Reinforced bitumen membranes for roofing — Code of practice*
- BS 8218 : 1998 *Code of practice for mastic asphalt roofing*
- BS 8417 : 2011 + A1 : 2014 *Preservatives of wood — Code of practice*
- BS 8747 : 2007 *Reinforced bitumen membranes (RBMs) for roofing — Guide to selection and specification*
- BS EN 1991-1-2 : 2002 *Eurocode 1 — Actions on structures — General actions — Actions on structures exposed to fire*
- BS EN 1991-1-4 : 2005 *Eurocode 1 — Actions on structures — General actions — Wind actions*
- NA to BS EN 1991-1-4 : 2005 *UK National Annex to Eurocode 1 — Actions on structures — General actions — Wind actions*
- BS EN 12056-3 : 2000 *Gravity drainage systems inside buildings — Roof drainage, layout and calculation*
- BS EN 13163 : 2012 + A1 : 2015 *Thermal insulation products for buildings — Factory made expanded polystyrene (EPS) products — Specification*
- BS EN 13501-1 : 2007 + A1 : 2009 *Fire classification of construction products and building elements — Classification using test data from reaction to fire tests*
- BS EN 13948 : 2007 *Flexible sheets for waterproofing — Bitumen, plastic and rubber sheets for roof waterproofing — Determination of resistance to root penetration*
- BS EN 15026 : 2007 *Hygrothermal performance of building components and building elements — Assessment of moisture transfer by numerical simulation*
- BS EN ISO 6946 : 2007 *Building components and building elements — Thermal resistance and thermal transmittance — Calculation method*
- BS EN ISO 9001 : 2008 *Quality management systems — Requirements*
- BS EN ISO 14001 : 2004 *Environmental management systems — Requirements with guidance for use*
- BRE Report BR 262 : 2002 *Thermal insulation: avoiding risks*
- BRE Report BR 443 : 2006 *Conventions for U-value calculations*
- ETAG 031 : 2010 *Guideline for European Technical Approval of Inverted Roof Insulation Kits*
- The Green Roof Guide*

## 16 Conditions

16.1 This Certificate:

- relates only to the product/system that is named and described on the front page
- is issued only to the company, firm, organisation or person named on the front page — no other company, firm, organisation or person may hold or claim that this Certificate has been issued to them
- is valid only within the UK
- has to be read, considered and used as a whole document — it may be misleading and will be incomplete to be selective
- is copyright of the BBA
- is subject to English Law.

16.2 Publications, documents, specifications, legislation, regulations, standards and the like referenced in this Certificate are those that were current and/or deemed relevant by the BBA at the date of issue or reissue of this Certificate.

16.3 This Certificate will remain valid for an unlimited period provided that the product/system and its manufacture and/or fabrication, including all related and relevant parts and processes thereof:

- are maintained at or above the levels which have been assessed and found to be satisfactory by the BBA
- continue to be checked as and when deemed appropriate by the BBA under arrangements that it will determine
- are reviewed by the BBA as and when it considers appropriate.

16.4 The BBA has used due skill, care and diligence in preparing this Certificate, but no warranty is provided.

16.5 In issuing this Certificate, the BBA is not responsible and is excluded from any liability to any company, firm, organisation or person, for any matters arising directly or indirectly from:

- the presence or absence of any patent, intellectual property or similar rights subsisting in the product/system or any other product/system
- the right of the Certificate holder to manufacture, supply, install, maintain or market the product/system
- actual installations of the product/system, including their nature, design, methods, performance, workmanship and maintenance
- any works and constructions in which the product/system is installed, including their nature, design, methods, performance, workmanship and maintenance
- any loss or damage, including personal injury, howsoever caused by the product/system, including its manufacture, supply, installation, use, maintenance and removal
- any claims by the manufacturer relating to CE marking.

16.6 Any information relating to the manufacture, supply, installation, use, maintenance and removal of this product/system which is contained or referred to in this Certificate is the minimum required to be met when the product/system is manufactured, supplied, installed, used, maintained and removed. It does not purport in any way to restate the requirements of the Health and Safety at Work etc. Act 1974, or of any other statutory, common law or other duty which may exist at the date of issue or reissue of this Certificate; nor is conformity with such information to be taken as satisfying the requirements of the 1974 Act or of any statutory, common law or other duty of care.